



This evaluation report draft is not valid until published and distributed.

DIVISION: 03—CONCRETE
Section: 03130—Permanent Forms

REPORT HOLDER:

ESR-2013

LITE-FORM TECHNOLOGIES
1950 WEST 29th STREET
SOUTH SIOUX CITY, NEBRASKA 68776
(402) 241-4402
www.liteform.com
general@liteform.com

Issued August 1, 2006

ADDITIONAL LISTEES:

BENCHMARK FOAM, INC.
3200 9TH AVENUE, SE
WATERTOWN, SOUTH DAKOTA 57201-9102

OWENS CORNING WORLD HEADQUARTERS
ONE OWENS CORNING PARKWAY
TOLEDO, OHIO 43659

EVALUATION SUBJECT:

FOLD-FORM INSULATING CONCRETE FORMS

1 **1.0 EVALUATION SCOPE**

2 **Compliance with the following codes:**

- 3 ■ 2003 *International Building Code*[®] (IBC)
- 4 ■ 2003 *International Residential Code*[®] (IRC)
- 5 ■ 1997 *Uniform Building Code*[™] (UBC)

6 **Properties evaluated:**

- 7 ■ Structural
- 8 ■ Surface-burning characteristics

9 **2.0 USES**

10 Fold-Form Insulating Concrete Forms (ICFs) are used as stay-in-place formwork for
11 structural concrete, load-bearing and nonload-bearing, below-grade or above-grade
12 walls, including reinforced concrete beams and lintels, and exterior, interior,
13 foundation and retaining walls. The Fold-Form forms are recognized for use in
14 buildings of Type V-B (IBC) and V-N (UBC) construction and buildings constructed
15 under the IRC.

16 **3.0 DESCRIPTION**

17 **3.1 General:**

18 Fold-Form ICFs are expanded polystyrene (EPS) interlocking rigid polystyrene foam
19 plastic boards that serve as stay-in-place formwork and are classified as flat ICF
20 wall systems in accordance with Section R611.3 of the IRC. The interior of a
21 building constructed with the Fold-Form ICFs shall be protected with an approved
22 thermal barrier, such as a 1/2-inch-thick (12.7 mm) regular gypsum wallboard, and
23 the exterior surface shall be covered with an approved exterior wall covering.

24 **3.2 Materials:**

25 **3.2.1 Fold-Form Insulating Concrete Forms:** The Fold-Form insulating units
26 consist of two EPS foam plastic boards separated by high-impact polypropylene
27 ties, which are factory-inserted into premolded slots in the EPS mold after molding
28 so that the flanges of the ties are recessed in the EPS boards. The ties, which are
29 spaced 8 inches (203 mm) on center horizontally and 8¹/₄ inches (2 mm) vertically,
30 are available in different lengths to retain the opposing EPS boards at fixed clear

31 distances of 4 inches (102 mm) to 16 inches (406 mm). The EPS boards are 12
32 inches (305 mm) high, 48 inches (1220 mm) long and 2 inches (51 mm) thick. When
33 stacked in a running bond pattern, the EPS units form a cavity where steel
34 reinforcement bars and concrete are placed. Refer to Figure 1 of this report for
35 details.

36 The EPS foam boards are molded from expandable polystyrene beads and comply
37 with Type IX EPS classification requirements in accordance with ASTM C 578. The
38 foam plastic has a minimum density of 1.80 pcf (28.8 kg/m³), and has a maximum
39 flame-spread index of 25 and a maximum smoke-density index of 450 when tested
40 in accordance with ASTM E 84 or UBC Standard 8-1.

41 The plastic ties are manufactured from high-density polypropylene in various lengths
42 of 2-inch (51 mm) increments, and have 1¹/₄-inch-wide-by-2³/₁₆-inch-high (32 mm by
43 56 mm) flanges. The plastic tie flanges, which are recessed ¹/₂ inch (13 mm) below
44 the outside surface of the EPS boards, provide a mechanism for attaching interior
45 and exterior wall coverings.

46 **3.2.2 Concrete:** Normal-weight concrete with maximum ³/₄-inch-size (19 mm)
47 coarse aggregate and a maximum slump of 6 inches (152 mm) must have a 28-day
48 minimum compressive strength of 2,500 psi (17.2 MPa), and must comply with
49 Sections 1903, 1904 and 1905 of the IBC or UBC. If construction of the Fold-Form
50 units is based on the IRC, concrete shall comply with IRC Sections R404.4.5 and
51 R611.6.1.

52 **3.2.3 Reinforcement:** Deformed steel reinforcement bars shall have a minimum
53 yield stress of 40,000 psi (276 kPa), and shall comply with Section 1903.5 of the
54 IBC or UBC. If construction of the Fold-Form ICFs is based on the IRC, reinforcing
55 steel shall comply with Sections R404.4.6 and R611.6.2 of the IRC.

56 **3.2.4 Other Components:** Wood members in contact with concrete shall be
57 treated with an approved wood preservative in accordance with the applicable code,
58 and attached with hot-dipped galvanized steel fasteners in accordance with Section
59 2304.9.5 of the IBC, Section R319.3 of the IRC, or Section 2304.3 of the UBC, as
60 applicable. Materials other than wood, such as vinyl, are permitted for window and
61 door framing if approved by the code official.

62 **4.0 DESIGN AND INSTALLATION**

63 **4.1 Design:**

64 **4.1.1 IBC or UBC Method:** Design of concrete in the Fold-Form ICFs shall comply
65 with Chapters 16 and 19 of the IBC or UBC, as applicable. Walls shall be anchored
66 to floors and roofs in accordance with Section 1604.8.2 of the IBC or Section
67 1633.2.8 of the UBC. The details in Figures 1 and 2 are illustrative only and shall be
68 qualified by design.

69 **4.1.2 Alternate UBC Design Method:** In lieu of calculations required by Section
70 4.1.1 of this report, the structural design of residential buildings constructed with the
71 Fold-Form ICFs and regulated by the UBC is permitted to comply with the
72 Prescriptive Method for Insulating Concrete Forms in Residential Construction
73 (publication No. EB118), dated May 1998, published by the Portland Cement

74 Association (PCA), subject to all applicability limits for a flat ICF wall system
75 specified in that document. The EB118 document shall be made available to the
76 code official upon request. Buildings constructed with the Fold-Form ICFs and
77 designed in accordance with this section (Section 4.1.2) shall not exceed a height of
78 two stories plus a basement, where the maximum unsupported wall height is 10 feet
79 (3048 mm).

80 **4.1.3 IRC Method:** Insulating concrete foundations and walls constructed with the
81 Fold-Form ICFs comply with IRC Figure R611.3 as flat insulating concrete wall
82 forms. Foundation and wall design, construction and materials shall be in
83 accordance with Section R404.4 or R611 of the IRC, respectively.

84 When the Fold-Form ICFs are used to construct buildings that do not conform to the
85 applicability limits of IRC Sections R404.4.1 and R611.2, the structural analysis and
86 design of the concrete shall be in accordance, respectively, with ACI 318 and
87 Chapter 19 of the IBC. Use of the empirical design approach specified in Section
88 14.5 of ACI 318 (IBC) is permitted for the design of concrete walls formed by the
89 Fold-Form flat-wall forms.

90 **4.2 Installation:**

91 **4.2.1 General:** The Fold-Form ICFs shall be installed in accordance with the
92 manufacturer's published installation instructions, this report and the applicable
93 code. A copy of the manufacturer's instruction shall be available at all times on the
94 jobsite during installation.

95 The Fold-Form ICFs shall be supported on concrete footings complying with
96 Chapter 18 of the IBC or UBC, or Chapter 4 of the IRC.

97 Vertical rebar, embedded in the footing, shall extend a minimum of 24 inches (610
98 mm) into the block wall system. Greater extensions may be specified by the design.
99 The Fold-Form units shall be stacked in a running bond pattern such that the webs,
100 which are spaced 8 inches (203 mm) on center horizontally, align vertically. Vertical
101 and horizontal reinforcement bars shall be placed as required by design and the
102 applicable code.

103 In jurisdictions adopting the IBC or IRC, all horizontal and vertical reinforcement
104 bars must have minimum concrete protection in accordance with the applicable
105 code. Concrete quality, mixing, and placing shall comply with Chapter 19 of the UBC
106 or the IBC.

107 In jurisdictions adopting the IRC, reinforcing steel for concrete formed by the
108 Fold-Form EPS units used above grade shall comply with Section R611 of the IRC.

109 Where wood ledgers are to be attached to the concrete wall, the face shell of the
110 EPS units is removed, with the height of the removed portion equal to the depth of
111 the wood ledger (see Figure 2). When concrete is poured into the wall system, the
112 concrete-filled volume, provided for the anchor bolts, forms a solid concrete
113 connection from the ledger board to the wall. The spacing and embedment depth of

114 anchor bolts shall comply with the design or the code requirement, whichever
115 governs. Anchor bolts used to connect the wood ledgers or plates to the concrete
116 shall be cast-in-place, with the bolts sized and spaced as required by design. Refer
117 to Figure 2 for typical details.

118 **4.2.2 Interior Finish:** Fold-Form ICFs exposed to the interior of the building shall
119 be finished with an approved 15-minute thermal barrier, such as minimum
120 $\frac{1}{2}$ -inch-thick (12.7 mm) regular gypsum wallboard, complying with ASTM C 36,
121 attached to the flanges of the plastic ties. The minimum $\frac{1}{2}$ -inch-thick (12.7 mm)
122 regular gypsum wallboard shall be installed vertically and attached to the plastic ties
123 with $1\frac{1}{2}$ -inch-long (38 mm), No. 6, Type S, coarse-thread screws complying with
124 ASTM C 1002 spaced 8 inches (203 mm) on center, horizontally, and alternating
125 between 5 and 7 inches (127 and 178 mm) on center, vertically.

126 **4.2.3 Exterior Finish:**

127 **4.2.3.1 Above Grade:** When regulated by the IBC or UBC, the walls shall be
128 covered on the exterior with an approved wall covering in accordance with the
129 applicable code or a current ICC-ES evaluation report. When regulated by the IRC,
130 the walls shall be covered on the exterior with a water-resistive barrier in accordance
131 with Sections R703.1 and R703.2 of the IRC, and an approved wall covering in
132 accordance with the IRC or a current ICC-ES evaluation report. The water-resistive
133 barrier, when attached to the flanges of the ties, requires use of minimum
134 $1\frac{1}{2}$ -inch-long (38 mm), No. 6, Type S, coarse-thread, corrosion-resistant screws
135 complying with ASTM C 1002.

136 An approved exterior wall covering shall be designed and installed in accordance
137 with the applicable code or an ICC-ES evaluation report. The wall covering, when
138 attached to the flanges of the ties, requires corrosion-resistant, No. 6, Type S,
139 coarse-thread screws complying with ASTM C 1002. The screws have a 35-pound
140 (156 N) allowable pullout capacity and a 35-pound (156 N) lateral capacity when
141 installed such that the screws protrude through the flange of the plastic tie a
142 minimum of $\frac{9}{16}$ inch (14 mm).

143 The fastener spacing shall be designed to support the gravity loads of the wall
144 covering and resist the negative wind pressures. Negative wind pressure capacity of
145 the exterior finish material shall be as recognized in the applicable code for generic
146 materials or in a current ICC-ES evaluation report for proprietary materials.

147 **4.2.3.2 Below Grade:** Wall surfaces shall be damp-proofed and, when
148 required by the code official, waterproofed in accordance with Section 1807.3 of the
149 IBC, or Section R404.4.11 of the IRC, or Appendix Chapter 18 of the UBC. Damp-
150 proofing and waterproofing materials shall be approved by Lite-Form Technologies
151 or Owens Corning World Headquarters and the code official, and shall be free of
152 solvents that will adversely affect the EPS foam units. Compliance is required with
153 drainage requirements in IBC Section 1807.4, IRC Section R405.1, or UBC Section
154 1804.7. No backfill shall be permitted to be applied against the wall until the
155 complete floor system is in place, unless the wall is designed as a freestanding wall
156 that does not rely on the floor system for structural support.

157 **4.2.4 Foundation Walls:** The wall system is permitted to be used as a foundation
158 stem wall when supporting wood-framed or concrete construction and when the
159 structure is supported on concrete footings complying with the applicable code.
160 Installation of Fold-Form units as foundation walls shall comply with Section 1805.5
161 of the IBC or Section R404.4 of the IRC, as applicable. In jurisdictions adopting the
162 UBC, compliance with UBC Table 18-I-C is mandatory.

163 **4.2.5 Retaining Walls:** Fold-Form ICFs are permitted to be used to form concrete
164 retaining walls with reinforcement designed in accordance with accepted
165 engineering principles and Section 4.1.1 of this report.

166 **4.2.6 Protection Against Termites:** In jurisdictions that have adopted the IRC,
167 where the probability of termite infestation is defined as “very heavy” by the code
168 official, the foam plastic shall be installed in accordance with Section R320.4 of the
169 IRC. Areas of very heavy termite infestation shall be determined in accordance with
170 Figure R301.2(6) of the IRC.

171 **4.3 Crawl Space Installations:**

172 The Fold-Form Insulating Concrete Forms are permitted to be used as walls of crawl
173 spaces without a covering applied to the crawl space side of the foam plastic,
174 provided all the following conditions are met:

- 175 a. Entry to the crawl space is only to service utilities, and no heat-producing
176 appliances are permitted.
- 177 b. There are no interconnected basement areas.
- 178 c. Air in the crawl space is not circulated to other parts of the building.

- 179 d. Under-floor ventilation is provided that complies with IBC Section 1203.3, IRC
180 Section R408 or UBC Section 2306.7.
- 181 e. Products are designated as Fold-Form and are manufactured using the bead
182 suppliers and bead types listed in the approved quality control manual and
183 recognized in a current evaluation report for attic and crawl space installation
184 without an ignition barrier.

185 **4.4 Special Inspection:**

186 **4.4.1 IBC:** Special inspection shall be required as noted in IBC Section 1704 for
187 placement of reinforcing steel and concrete, and for concrete cylinder testing.
188 Special inspection, in accordance with IBC Sections 1704.1 and 1704.12, is required
189 when an EIFS wall covering is applied. Duties of the special inspector shall include
190 verifying field preparation of materials, expiration dates, installation of components,
191 curing of components, and installation of joints and sealants.

192 **4.4.2 IRC:** For walls designed and constructed in accordance with the IRC and
193 Section 4.1.3 of this report, special inspection shall not be required. For walls
194 designed and constructed in accordance with the IBC, as permitted by IRC Sections
195 R104.11 and R301.1.3, special inspection in accordance with Section 4.4.1 of this
196 report shall be required.

197 **4.4.3 UBC:** Special inspection shall be required as noted in UBC Section 1701 for
198 placement of reinforcing steel and concrete, and for concrete cylinder testing. When
199 approved by the code official, special inspection may be waived when all of the
200 following conditions are met:

- 201 a. Walls are a maximum of 8 feet (2.4 m) high, and are limited to use in single-
202 story construction of Group R, Division 3, or Group U, Division 1,
203 Occupancies.
- 204 b. Concrete is placed in a continuous operation and in uniform lifts of no more
205 than 48 inches (1219 mm). Succeeding lifts shall be placed in accordance
206 with UBC Section 1905.10.5.
- 207 c. Installations shall be done by properly trained installers approved by Lite-
208 Form Technologies or Owens Corning World Headquarters.
- 209 d. The manufacturer's published installation instructions indicate methods used
210 to verify proper placement of concrete.
- 211 e. Half the allowable stresses or loads permitted by the UBC are used for the
212 design of the walls.

213 **5.0 CONDITIONS OF USE**

214 The Fold-Form Insulating Concrete Forms described in this report comply with, or
215 are suitable alternatives to what is specified in, those codes listed in Section 1.0 of
216 this report, subject to the following conditions:

217 **5.1** Foam units must be manufactured, identified and installed in accordance with
218 this report and the manufacturer's installation instructions and applicable
219 codes. In the event of a conflict between this report and the manufacturer's
220 instructions, this report governs.

221 **5.2** When regulated by the IBC or UBC, walls constructed with the Fold-Form
222 Insulating Concrete Forms are limited, respectively, to Type V-B or Type V-N
223 nonfire-resistance-rated construction.

246 **5.9** The Fold-Form Insulating Concrete Forms are manufactured in Watertown,
247 South Dakota, under a quality control program with inspections conducted by
248 RADCO (AA-650).

249 **6.0 EVIDENCE SUBMITTED**

250 Data in accordance with the ICC-ES Acceptance Criteria for Concrete Floor, Roof
251 and Wall Systems and Concrete Masonry Wall Systems (AC15), dated June 2003,
252 and the ICC-ES Acceptance Criteria for Foam Plastic Insulation (AC12), dated June
253 2006; including ASTM C 578 and UBC 26-3 test data.

254 **7.0 IDENTIFICATION**

255 Each package of forms bears a label specifying the name and address of the
256 evaluation report holder (Lite-Form Technologies; South Sioux City, Nebraska) or
257 one of the additional listees (Benchmark Foam, Inc., or Owens Corning World
258 Headquarters). Additionally, product labels indicate the evaluation report number
259 (ESR-2013) and the name of the inspection agency (RADCO).

260 This evaluation report is subject to re-examination in one year.

ME/II

TOP VIEW

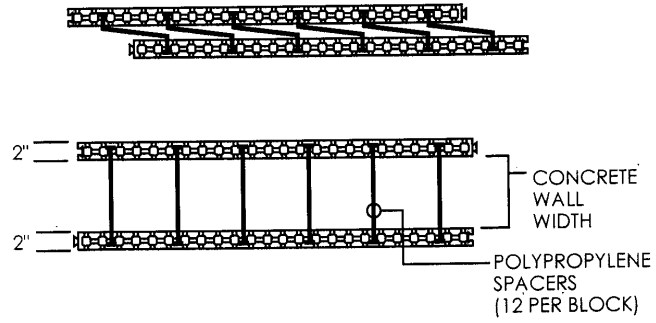

SIDE VIEW

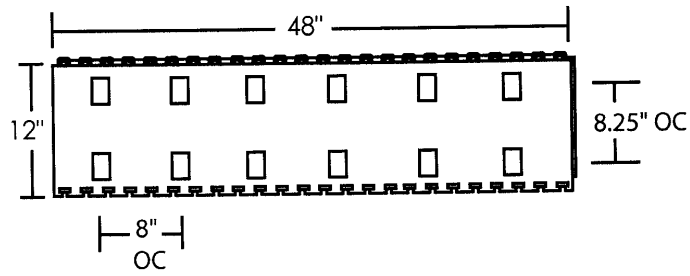
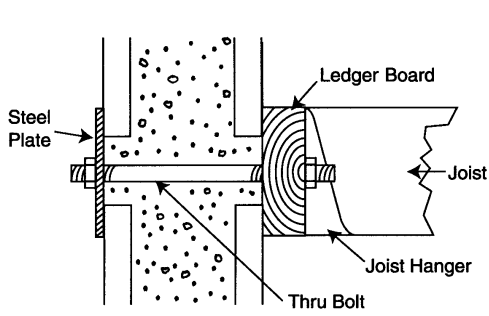
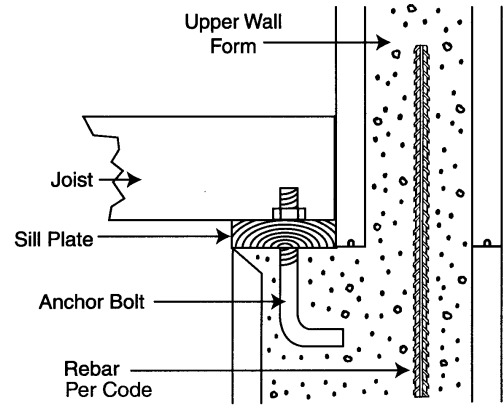

FIGURE 1—FOLD-FORM DIMENSIONS—FULL BLOCK



Common Concrete Wall, Ledger with Thru-Bolt Connection



Common Concrete Wall, Top-Bearing Connection

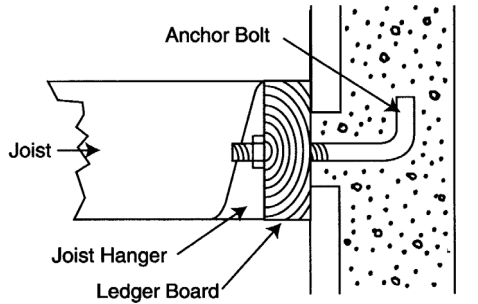

Common Concrete Wall, Ledger with Side-bearing Connection

FIGURE 2—TYPICAL CONNECTION DETAILS